







## InCarTec FK-853-5

### Component List

Part Number	Component	Image
50-786 & 51-012	Fascia/Fitting Cage	
20-313	Amplifier Bypass Cable	
29-713	Steering Control Interface harness	
21-106	LVDS Cable	
MOST-LOOP-F (included in 29-713)	Fibre optic loop	
29-025	Universal Patch Lead	
CAB-MOST-100M	Fibre optic extension cable	

### Installing the cage and fascia (51-012 & 50-786)

1. Ensure your vehicle's ignition is off with the key removed.
2. Remove the original Head Unit (radio) with reference to the manufacturer's instructions.
3. Fit the new fitting cage and fascia into the car. You can discard any fitting cage that came with the new Head Unit you are fitting.

### Connecting the interface (29-713)

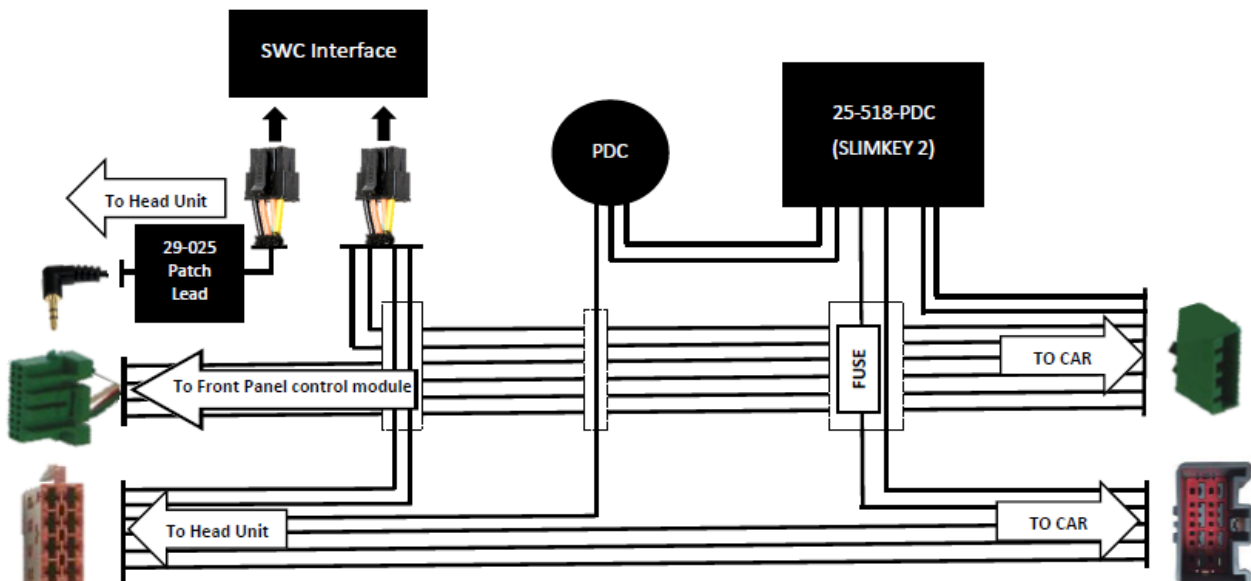

1. Assemble the Universal Patch Lead (29-025) with reference to the given instructions with the Patch Lead
2. Connect the patch lead to the new Head Unit and then to the Steering Control Interface (Black box on 29-713 harness). **THIS MUST BE DONE FIRST BEFORE ANY OTHER CONNECTIONS.**
3. Disconnect the large male connector from the rear of the original Head Unit and connect the large female connector of the interface harness to this. Then remove 10-pin connector and connect the smaller green female connector of 29-713 to this.
4. Connect the male green 10-pin connector and ISO connector to the Head unit.

## Relocating the Control Module

**IMPORTANT - The original Alpine amplifier needs to stay powered and connected to the fibre optic network.**

The control module connected to the front button panel needs to remain powered and connected in the car, this fitting kit has extension leads (CAB- MOST-100) to relocate this module to the passenger footwell. The footwell panel can be easily removed and the button panel reattached to the module to allow the time and date settings to be updated.

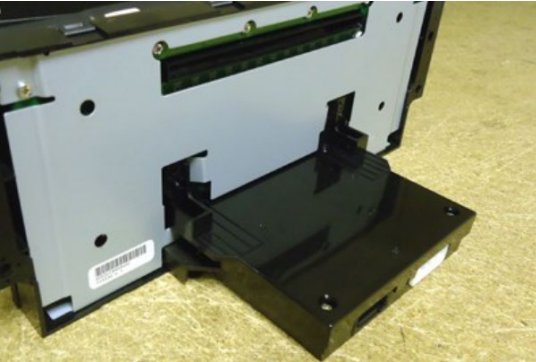

1. Undo the screws holding the control module to the front button panel

2. Feed the extended fibre optic and green data connectors through the hole under the radio and down to the passenger footwell where the control module will be relocated to.



3. The module can be easily accessed Using the original button panel the time settings on the display can be updated



4. Remove the black fibre optic connector from the rear of the standard head unit and connect the fibre optic loop (MOST-LOOP-F) to this connector. (This ensures the fibre optic loop in the car is not broken).

### Bypassing the amplifier (20-313)

1. Locate the Amplifier in the vehicle, this is in the rear quarter of the vehicle. Disconnect the large connector from the amplifier and connect the Amplifier bypass cable (**20-313**) via the green connector.
2. Connect the other end of the bypass cable to the Head Unit. **The coloured wires on the bypass cable are for the addition of an extra amplifiers to the system or to connect to the existing subwoofer if one is in the vehicle.**

### Finally

**Test the system fully ensuring all controls function before refitting the new Head Unit.**

The parking sensor retention interface will also generate a CANbus ignition to the new head unit. The original display (navigation) above the radio will continue to work, however, there will be no audio from the screen.

### Troubleshooting

- Check that the correct patch lead has been used and links in the connector are in the correct place (Always disconnect from the power supply if you change the lead).
- Check that head-unit is grounded and the black wire is to ground

If the problem persists, go online to our website for more technical help.